



# SOLUTION-BASED WASTEWATER TECHNOLOGY

Pumps and grinders for sewage treatment plants  
and sewer systems

**VOGELSANG – LEADING IN TECHNOLOGY**

**VOGELSANG**







# You can rely on it

**Quality, experience and expertise guarantee future-proof technology**

**As the inventor of the elastomer-coated rotary lobe pump, Vogelsang has numbered among the world's leading mechanical engineering companies in the area of pumping and shredding technology for decades. Companies in the wastewater sector, especially those with the systems and plants that must comply with highly specialized preconditions, have learned to trust in the user-oriented design and outstanding quality of our systems.**

Based on our extensive experience and ongoing research, we develop components and systems with maximum functionality that ensure trouble-free, economical operation in the long term – also making sure they are easy to operate.

Both the production process and quality of our machines testify as to how seriously we take our commitment to providing our customers with the very best. Their adaptability and flexibility serve to increase efficiency and performance optimization as well as sustainability. All over the world, operators of sewage treatment plants and sewage systems rely on compact, highly resistant pump and grinder systems from Vogelsang in order to comply with the heightened requirements of modern wastewater collection and cleaning.

# Flow function rather than malfunction

## Reliable components for wastewater treatment and pumping

Our modern lifestyle and the throwaway mentality of many citizens is presenting operators of sewage systems and sewage treatment plants, such as wastewater authorities or municipal councils, with an ever-increasing problem: More and more waste in the form of sanitary products, fabrics and leftover foodstuffs are not thrown in the trash but end up in the toilet – and subsequently in the sewage system.

Due to the high proportion of fibers and disruptive matter, entangled material, fatbergs and deposits are being created that clog pumps, valves and wastewater pipes and damage them. Entire systems and plants are failing and often require repairs far too frequently. At the same time, as limit values become lower and lower, the polluting load in wastewater needs to be economically and reliably reduced.

To enable trouble-free and efficient wastewater cleaning, we at Vogelsang are developing special models of our pumps and grinders that are tailor-made for particular sectors. These comprise robust components, which help to pump sludge and wastewater reliably, prevent entangled materials, floating layers and damage from foreign matter and efficiently reduce the dirt load. All this with an easy-to-maintain structure that simplifies handling during maintenance. This saves time and lowers costs – a decisive contribution to ensuring efficient and economical operation of your wastewater treatment system.

### **Our knowledge advantage**

The components we develop and continually perfect have stood the test of time in thousands of applications all over the world. Research, continuous improvement and innovative features ensure smooth processes and hence minimum costs for wastewater treatment systems.

### **For cost-conscious wastewater cleaning**

The cost-effectiveness of a sewage treatment plant depends primarily on the efficiency and functionality of their components. Each of our components contributes to this while, at the same time, the coupling of harmonized Vogelsang machines using the latest control technology opens up additional potential for savings and even more economical procedures. In this way, we can not only offer extremely reliable products but also efficient complete packages in the area of pumping and grinding technology.

### **Quality management**

At Vogelsang, quality control is a basic tenet. None of our products leave the factory without being thoroughly checked. We are constantly taking our quality and environmental management system to the next level, and regularly earn certification in accordance with DIN EN ISO 9001:2015 or DIN EN ISO 14001:2015 – after all, those who fail to improve will surely be left behind

# Vogelsang technology for wastewater and sludge at a glance

## Rotary lobe pumps

---



### VX series

- Compact, high performance and easy to maintain
- Pumping direction can be changed as desired
- Suitable for a wide range of pumping tasks



### IQ series

- Especially easy to operate and maintain, thanks to their unique design
- Good suction capacity, dry-running resistant
- Straightforward integration into pipe systems

## Progressive cavity pumps

---



### HiCone®

- Several times longer service life
- Reduced lifecycle costs
- Optimal adjustment for maximum efficiency
- Features status indicator to avoid unexpected failures

## Grinder

---



### XRipper®

- Robust twin-shaft shredder
- Reduces solid and disruptive matter in wastewater reliably
- Protects pumps and systems from entangled materials and blockages
- Straightforward, easy maintenance on-site using own personnel



### RotaCut®

- Wet cutter and heavy material separator in one
- Reliable maceration of fibrous and coarse matter in liquid media
- Protects downstream components
- Optionally with online monitoring

# Constant performance, flexible applications

**Vogelsang rotary lobe pumps: the efficient choice for the widest variety of pumping tasks**

**Vogelsang rotary lobe pumps are known for their energyefficient pumping of wastewater and sludge, combined with their design that is easy to service and maintain. Two series are available for the area of wastewater technology.**

Particularly in the area of wastewater treatment, a reliable, efficient and high-performance pump that can handle a wide variety of media is essential. From wastewater with a high percentage of foreign and fibrous matter to highly viscous sludge, even when reduced beforehand, refuse and waste that land in the sewage system present a tough challenge for both the reliability and economic efficiency of a pump. Foreign bodies, disruptive matter and entangled material have a negative effect on the degree of efficiency and power requirements of a pump, and in the worst cases will lead to its failure.

It's no surprise that, as the inventor of the elastomer coated rotary lobe pump, Vogelsang is held in very high esteem in this sector. Our pumps are built for specific tasks and have become the standard worldwide for reliable and economical pump technology in many areas.

## **The principle**

Vogelsang rotary lobe pumps are contactless, rotating positive displacement pumps. The pulsation-free HiFlo rotary lobes enable extremely uniform pump performance that is low in vibrations. The delivery rate increases in proportion to the speed, meaning Vogelsang rotary lobe pumps have proven to be an efficient choice for virtually any type of pumping tasks in sewage treatment plants or sewage networks. Their unique design also makes them simple to handle and economical to operate.

## **The all-rounder**

The uses of Vogelsang pumps are virtually unlimited. They can even be used to pump abrasive fluids like primary sludge or thickened, viscous media.

## **Compact and space-saving**

These compact pumps can be integrated easily into any system and require 50 % less space than progressive cavity pumps. Vogelsang pumps are also very easy to retrofit in most cases.



Easy to service and maintain: the rotary lobe pumps of the IQ and VX series



### Practical, economical and easy to maintain

Vogelsang pumps are easy to operate and easy to maintain. This ensures low downtime, high availability and, above all, low operating costs.

### Drives

A selection of combustion, hydraulic and electric motors are available in different versions – driven by a geared motor or, as a more compact option, a belt with a piggyback electric motor. All pumps can be designed so that the control functions occur via a variable frequency drive to ensure optimal operation at all times.

### Sealing technology for professionals

For rapid and reliable seal replacement, cartridge mechanical seals have been the standard for years for all Vogelsang pumps. The completely pre-assembled units contain all components, thereby ensuring high availability and operational reliability. Special designs of 100 % tested seals, such as TA Luft\*-compliant, are available for use in wastewater cleaning.

### Vogelsang InjectionSystem

In conventional rotary lobe pumps, foreign and solid matter is caught in a vortex – which often results in damage as well as increased wear on the lobe tips. The innovative Injection-System enables foreign matter to be injected directly into the opening pump chambers. This prevents collisions with the lobe tips. The internal sealing of the pump is also increased.

The InjectionSystem does more than increase the intake capacity and efficiency of the pumps. The intelligent foreign matter handling increases the service life of the pump – up to 150 percent in field tests.

### Control technology

Our Performance Control Units (PCUs) enable a significant increase in the performance and efficiency of Vogelsang rotary lobe pumps. Pressure, power consumption, speeds, etc., are monitored constantly; the correlations between them are intelligently linked. In this way, the PCU is able to automatically register the load and ensure that the pump is operated in the optimum range, using appropriately defined control interventions.

\* TA Luft is the German air pollution control regulation.

### InjectionSystem

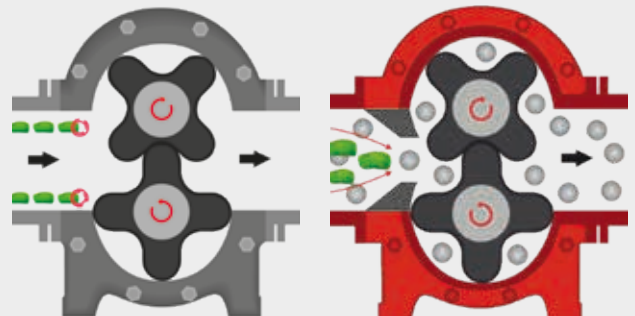

**Rotary lobe pump  
in conventional design**

**Rotary lobe pump  
with InjectionSystem**

### Advantages of Vogelsang pumps

- Minimal space requirement thanks to compact design
- Suitable for all applications with easy handling due to reversibility of pumping direction, self-priming and dry-running resistance
- Resistant to foreign matter thanks to the innovative InjectionSystem
- Economical operation thanks to high efficiency and pulsation-free HiFlo lobes
- Easy to maintain and easy to service, high availability thanks to low downtime

# Highly adept, established rotary power pack

The flexible VX series  
for task-oriented pumping



VX230-320Q rotary lobe pump

Vogelsang rotary lobe pumps of the VX series pump the widest variety of media, from low-viscosity fluids to highly viscous sludge. A worldwide easy-to-maintain classic among rotary lobe pumps, VX series pumps are available in five series. Depending on the application area and power requirements, they include up to eight different sizes with a specially designed version of the reliable rotary lobe pump available for virtually every delivery rate and differential pressure.

Each individual pump is configured accordingly to the application. The interior coating, lobe material and drive type are determined individually according to the need of your wastewater treatment plant or sewage system.

Besides wastewater and sludge, they also pump chemically aggressive media effectively and economically without any performance impairments.

#### **Faster access for less maintenance work**

Simply open the cover for easy access to the pump chamber thanks to the QuickService design. Wearing parts can be replaced quickly without completely removing them from the pipe and disassembling the pump. For greater stability when working with high pressures the QD version with third-bearing in the cover is used.

#### **Shaft warranty**

A large cross-section, no recesses – the result: Vogelsang pumps have break-resistant shafts! That is why we provide a five-year warranty against internal shaft breakage\* for all pumps in the VX series.

\* Under the normal conditions of use in accordance with our terms of warranty.

## **Special designs**

Upon request, we can also develop special designs inhouse to meet your specific requirements. For example:

- Multi-chamber pumps
- Long-shaft pumps
- Immersion motor pumps
- Mobile pump units
- Combinations of drives
- ATEX-compliant



#### **Advantages of the VX series**

- Comprehensive range of features and options
- Quick access to the pump chamber by removing the cover
- Simple on-site service and maintenance
- Self-priming and dry-running resistance
- Shaft warranty

# Service and handling made even simpler

The highly economical IQ series for maximum performance yet less work

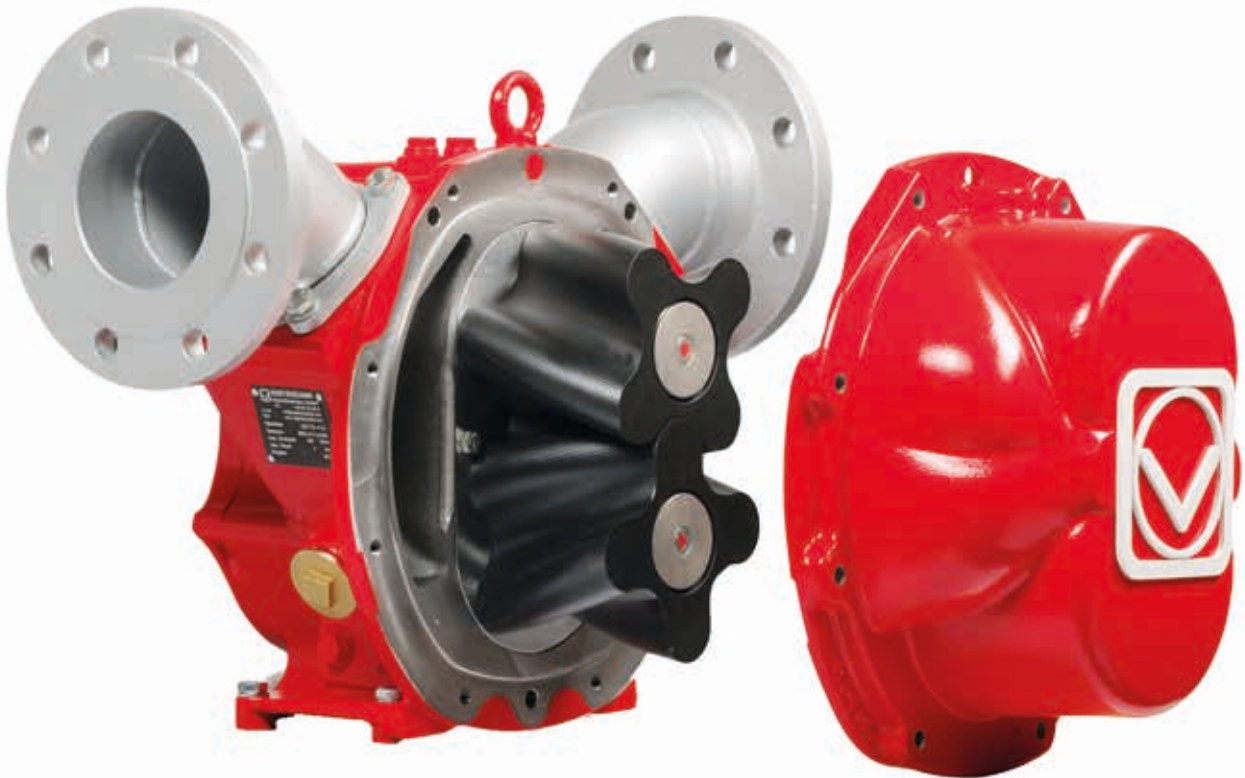



With its design reduced to just a few individual elements that makes handling even easier compared to rotary lobe pumps of the VX series, the Vogelsang IQ series is proof that even successful technology is worth redesigning.

IQ series rotary lobe pumps are also equipped with the tried-and-tested pulsation-free HiFlo rotary lobe. The unique InjectionSystem makes it just as resistant to foreign matter as it is to dry running and protects the lobes from damage, thereby ensuring good suction capacity. In contrast to the pumps of the VX series, the pump housing of the IQ series consists of just a single component; however, it can be dismantled with just a few movements, giving access to the pump elements, while the pump remains firmly screwed into the pipe.



### Long service life and low operating costs

As well as the gentle InjectionSystem, the simplified design also helps to lower costs. Since the number of central spare parts is reduced by half, compared to the conventional design, the outlay for spare parts is also reduced. In addition, less time is required for maintenance and replacement of parts. Pumps of the IQ series are designed so that replacement of all wearing parts – including rotary lobes, plates, pump housings and seals – takes less than half of the usual time.

### Simple integration

The variable series connecting parts on IQ series pumps are suitable for the most common installation situations. This means that they can be quickly and easily attached or installed in a wide range of positions, including to tank vehicles and mobile units, without the need for special connections.



IQ152 on torsion-resistant base. The flexible connecting parts enable simple adaptation to common installation situations.



### Advantages of the IQ series

- Quick and convenient access to pumping elements
- Intelligent, integrated foreign matter handling
- Excellent suction capacity and integrated dry-running protection
- Significantly reduced spare parts costs

# The pump revolution

The unique HiCone<sup>®</sup> progressive cavity pump with groundbreaking adjustment system

Pressure-stable delivery rate

Patent pending adjustment system for minimal lifecycle costs

Unique conical geometry for several times longer service life

Minimal space requirement thanks to compact design

Easy parts replacement without dismantling the pipes

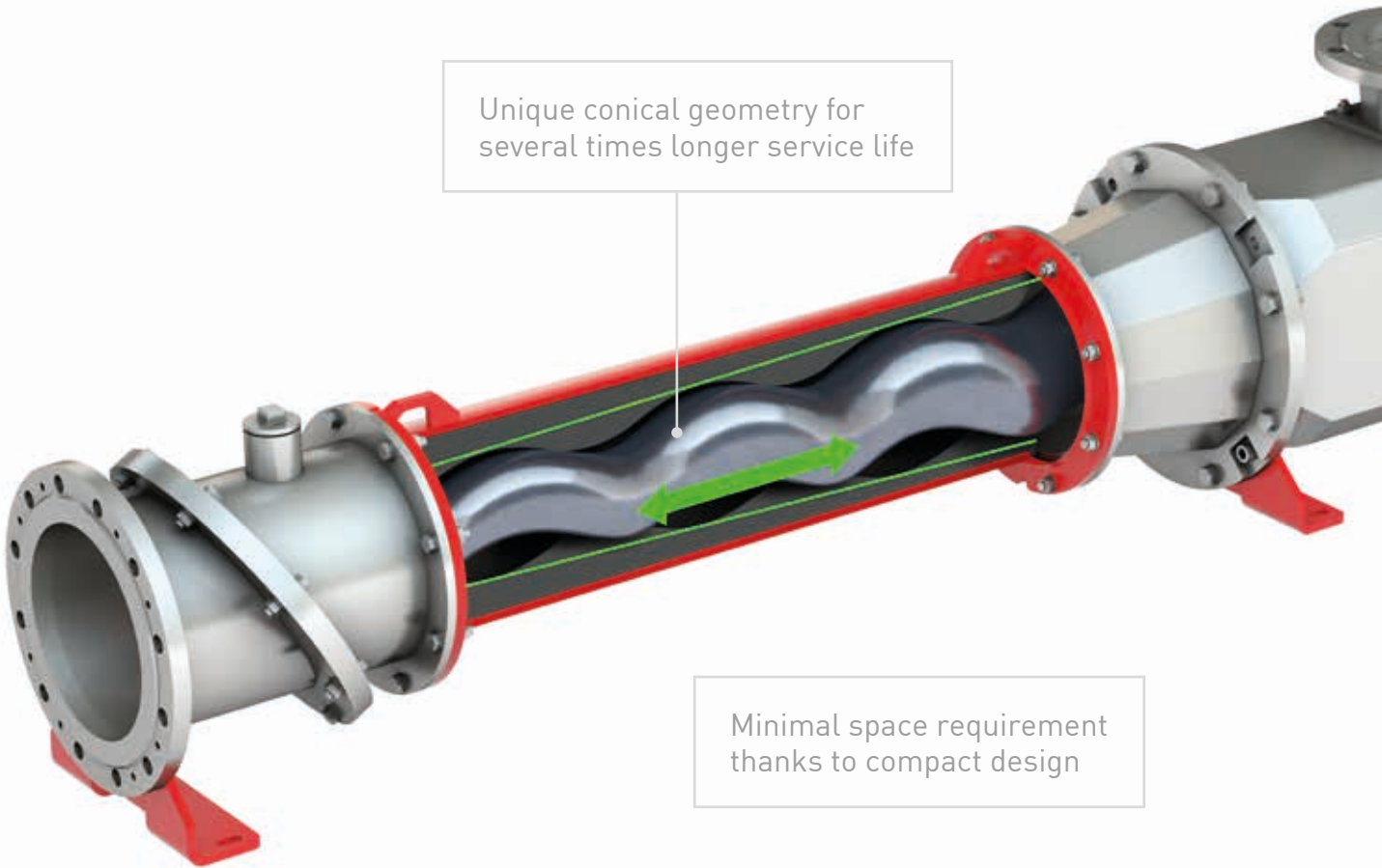

Adjustment of the pumping elements depending on the general conditions

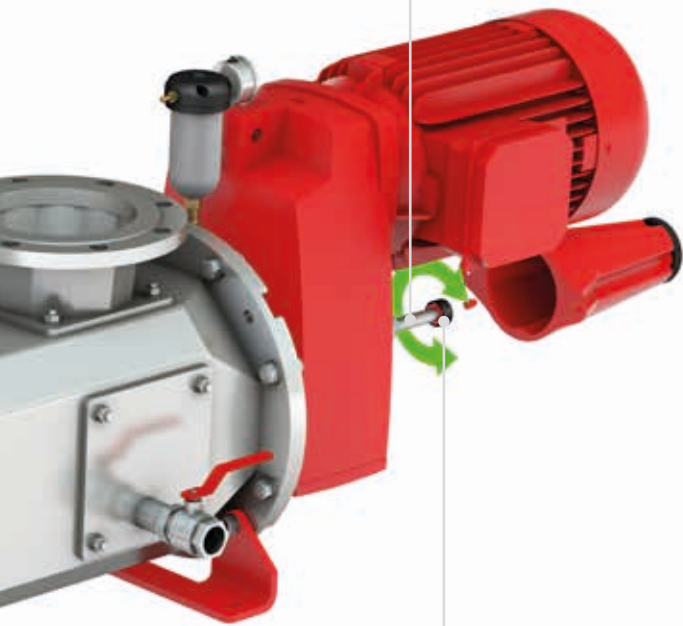

Display of the wear status

High delivery rates of up to 290 m<sup>3</sup> per hour

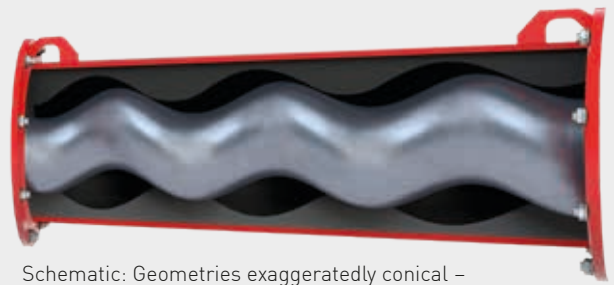

Schematic: Geometries exaggeratedly conical – in reality, stator is cylindrical outside.

### Unrivalled economy thanks to the conical shape for precise clamping

The unique, forward-tapering geometry of the rotor and stator enables both wear compensation and ideal adjustment to the given flow medium. Customers benefit from an unprecedented extension of service life and a far superior cost/ performance ratio when using a HiCone progressive cavity pump compared to conventionally designed models.



Thanks to a clever mechanism, the rotor and stator can be easily positioned to each other and their status checked.

### Advantage of the HiCone®

- Reduced lifecycle costs
- Several times longer service life
- Optimal adjustment for maximum efficiency
- Easy to maintain and low maintenance
- Features status indicator to avoid unexpected failures

# Optimally tuned for long service life

**The interplay of unique geometry and an innovative adjustment system saves energy and extends the service life of the new HiCone® progressive cavity pump**

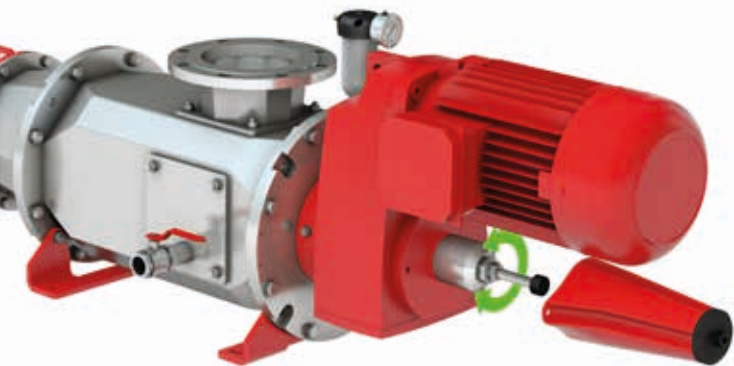

Adjustment and readjustment system of the HiCone progressive cavity pump

**In times of rising energy costs, trouble-free and efficient pumping processes are a necessity for the future. Energy- efficient and durable pumping technology is particularly important, as it consumes a considerable amount of the electrical energy generated. That is why Vogelsang has reinvented the progressive cavity pump.**

We have already made a decisive breakthrough that helps customers by implementing rapid parts replacement for pumps in the proven CC series. The new progressive cavity pumps of the HiCone series furthermore feature a revolutionary, conical geometry and clever adjustment system, which enables longer service life than ever before while significantly reducing overall lifecycle costs.

## **Simply adjust instead of replacing parts**

In conventional progressive cavity pumps, wear quickly leads to a gap between rotor and stator – causing an abrupt drop in pumping performance and requiring time-consuming part replacement. Since the condition of the conveying elements cannot be monitored, this loss in performance often comes as a surprise to the user. The innovative HiCone offers a smart solution: the gap is easily compensated by adjusting the rotor – maintaining consistently high performance without needing to replace parts. At the same time, the HiCone continuously monitors the condition of the conveying elements. This allows for timely ordering of spare parts and proactive maintenance planning – ensuring maximum operational reliability and minimal downtime.

## **Adjustable setting with extraordinarily easy handling**

In order to react to different pumping tasks, the clamping between the rotor and stator of the pumps can be adjusted accordingly. The precise adaptation of the pump elements to operating parameters such as pressure, viscosity or temperature minimizes energy consumption and wear. This ensures that the pump operates at its optimum operating point.

## **Maximum availability at the lowest possible power consumption**

The result: a service life that is several times longer and an extremely high availability compared to conventional progressive cavity pumps. This represents a significant cost advantage, especially since the lower power consumption, which is kept to a minimum, leads to further savings.

# A new era

## The pinnacle of efficiency: The durable HiCone® progressive cavity pump with QuickService functionality

The CC series pumps have already helped to avoid long downtimes thanks to their reliability and durability. And now, Vogelsang's HiCone series pumps require even less maintenance, thanks to the unique, conical geometry of the pumping elements and the associated adjustment and readjustment options. Users benefit from significantly longer service life and higher availability – leaving them with more time for essential tasks.



HiCone progressive cavity pump



The condition of the conveying elements can be easily checked. This allows necessary service operations to be identified early and planned efficiently. When it comes to part replacement, the proven **QuickService principle** is applied: thanks to the swiveling mechanism, the rotor and stator can be replaced quickly and easily – without removing the pump from the pipeline system. With just a few simple steps, the entire rotor/stator unit can be removed and replaced – including the drive shaft, if needed.

And replacing the pre-assembled mechanical seal is just as easy: it can be replaced from the side after removing the geared motor.



XRipper® XRP

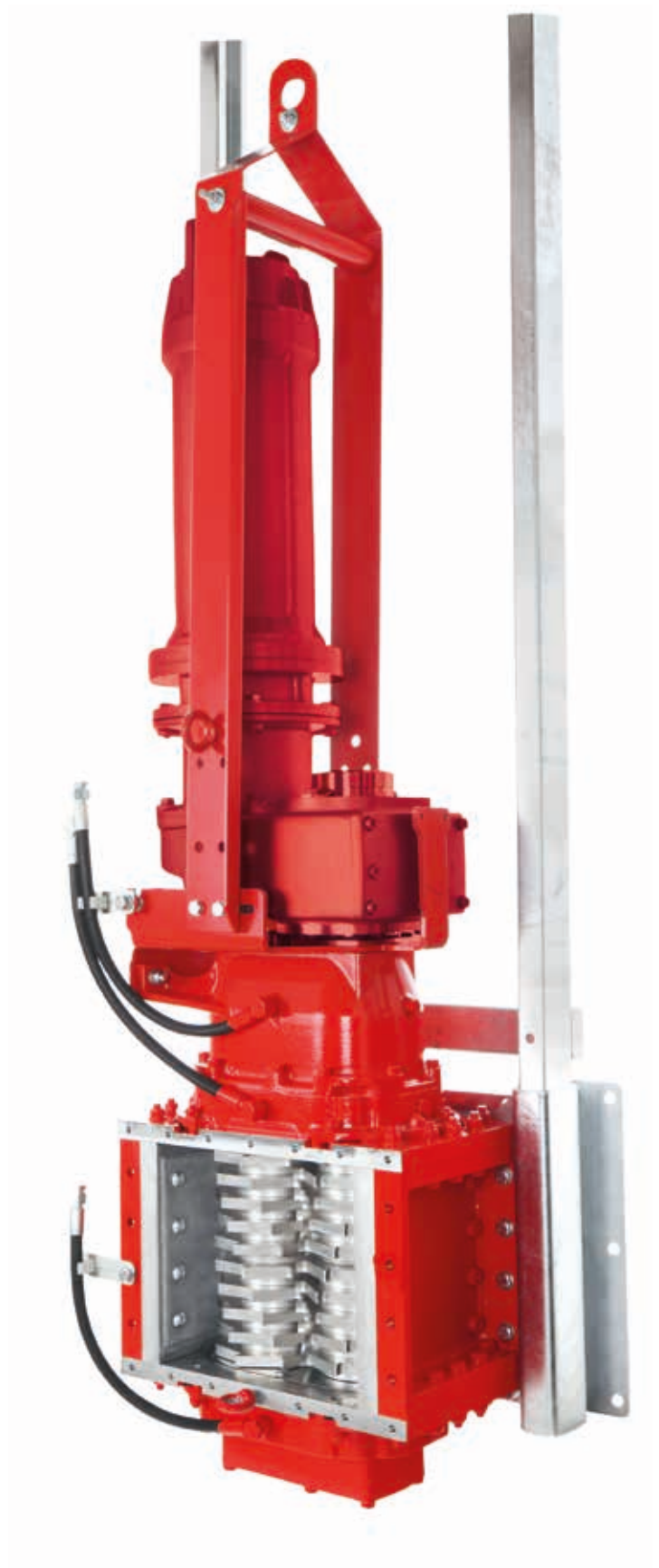

XRipper® XRC-SIK

# Major challenges? No problem!

## The ultra-robust XRipper® series twin-shaft shredder by Vogelsang

**Twin-shaft shredder by Vogelsang, based on monolithic Ripper rotors, deal reliably with entangled materials in digestion towers as well as disruptive matter, textiles, sanitary items and other fibrous matter in wastewater, thereby protecting downstream equipment from malfunctions.**

The blocking of sewer, pipes and pumps due to wet wipes and other sanitary items disposed of in the toilet is a topic much discussed in the media but constitutes serious problems for operators of sewage treatment plants and sewer systems. In conjunction with the (fortunately) lower water consumption, the way products from drugstores are being handled in modern life is leading to considerable difficulties. Entangled materials from digestion towers are also repeatedly causing malfunctions in plant operations. Both are leading to huge costs for wastewater associations and municipal authorities, and in larger cities they are costing millions.

One solution already used by numerous operators around the world is having an XRipper by Vogelsang connected upstream. As frequent malfunctions are time-consuming and onerous, investment in this twin-shaft shredder built from premium-quality, highly resistant material, will lead to a fast return on investment; the robust machine has proven time and time again that it can reduce the number of repair or maintenance visits required. Some customers have even registered a 100% success rate, with no further clogging issues.



More and more sanitary products and textiles are ending up in the sewage system, resulting in wastewater technology being rapidly overburdened. The XRipper by Vogelsang provides reliable protection from pumps and pipelines clogging.

**Speak to our specialist today to find out which XRipper® version is best for your needs.**

### **Advantages of the XRipper®**

- Economical shredding of solid and disruptive matter such as wet wipes, wood, fabric, trash and waste
- Efficient protection for pumps and system components from clogging, blockages and damage
- Long service life thanks to rugged design
- Fast access to all individual parts yet less service and maintenance work
- Added reliability thanks to cartridge mechanical seal technology

With its tried-and-tested twin shaft version, the XRipper has proven itself to be a resilient, economical solution for reducing disruptive matter to a manageable size. In this way it protects downstream equipment from clogging, blockages and damage.

### The principle

The Ripper rotors of the XRipper, with their one-piece construction, are installed such that they intermesh. Whereas water will pass by the XRipper more or less unobstructed, solid and disruptive matter such as sanitary products, wood, fabric or waste from food production, is detected by the Ripper rotors and shredded to a manageable size.

Another important factor is that the Ripper rotors clean themselves due to their different speeds.

### For greater power and efficiency

To attain maximum force transfer from shaft to the cutting elements, the monolithic Ripper rotors are manufactured from a single block of special steel or, optionally, from stainless steel. This leads to hard and precise cutting and thus an optimized cutting effect.

### Safe, easy to maintain and cost-efficient

The monolithic design of the Ripper rotors not only ensures particularly thorough shredding and fault-free flow of the treated wastewater, but it also has a positive effect on economic efficiency when it comes to maintenance of the shredder. This is due because, rather than lots of individual cutting rings and spacers, only the rotors, which consist of a single piece, need to be replaced. This simplifies assembly to save time and ensures greater safety.

All other service and maintenance work, such as the replacement of seals, can be performed on-site quickly. Here too, fully preinstalled cartridge mechanical seals are used, which can be replaced in their entirety, increasing the XRipper's already high level of availability even further.



# Pass every ripping test

The one-piece Ripper rotors of the XRipper® series offer outstanding shredding performance

## Unique design

Due to the great forces generated in the particularly challenging shredding processes used in sewers and wastewater treatment plants, robust machine design and construction is a high priority. For this reason, high-precision CNC machines are used to manufacture each of the one-piece Ripper rotors by Vogelsang from a single block of special steel. The unique design has a high-strength core, especially narrow gaps and hardened, durable cutting edges. Even without the carrier shafts which usually run through the entire unit, the drive output is transferred evenly along the entire length of the monolithic rotors. Intermediate bearings are not necessary thanks to the high bending stiffness. Moreover, the most advanced production methods also ensure minimum tolerances, so highly efficient shredding can also be guaranteed over the long term.

Another advantage of this unique design – easy part replacement! Instead of exchanging many individual disks and spacers on the carrier shafts, only the one-piece Ripper rotors need to be replaced. Due to the symmetrical design, they can also be rotated 180 degrees. In addition, on the XRP, XRC and XRG models, the entire functional unit – which consists of the motor, gearbox, Ripper rotors and counter bearings – can simply be lifted out of the housing in one piece. The housing remains in place while all of the parts that are important for service and maintenance are easy to access.

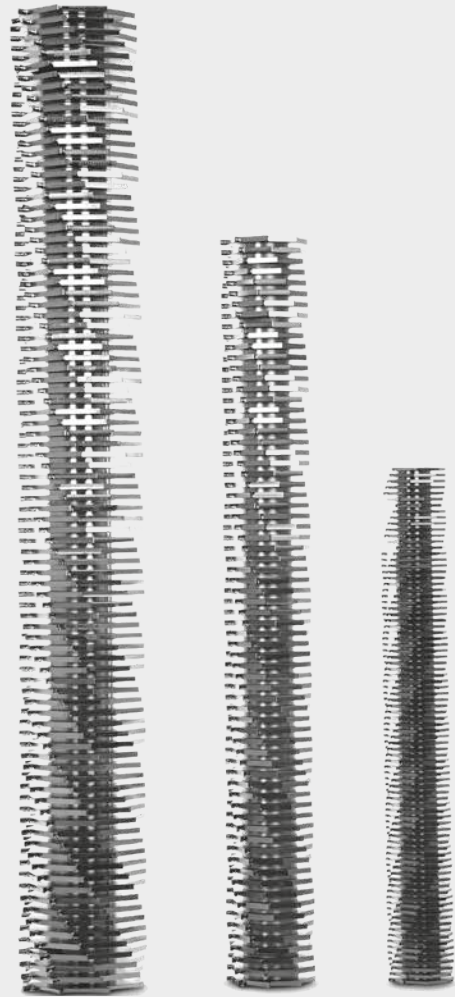

The monolithic one-piece Ripper rotors are extremely rigid and especially easy to maintain.



# Rely on experience and understanding

## The right grinder for every application

With all XRippers, the low speed of the Ripper rotors means high torques are available for shredding at low drive powers. At the same time, thanks to their contact-less principle of operation, power take-up at no load is minimal. Optimally adapted to the special requirements of wastewater technology, the XRipper is available in four different designs.



### **XRipper® XRS**

#### **The versatile and easy-to-maintain series**

The XRipper XRS is an economical solution when you need to shred solid and disruptive matter in municipal or industrial wastewater to a manageable size. The sturdy construction and an extensive range of features and options make for a cost-effective solution whatever the application. The XRS is also impressive due to its easy-to-maintain and simple-to-repair design: All necessary service and maintenance work can be performed quickly and easily on-site, without having to dismantle the grinder.

- The easy-to-maintain standard version with horizontal Ripper rotors
- Highly flexible due to the wide range of adaptation options



### **XRipper® XRP**

#### **The compact inline variant for pipe systems**

The XRP provides reliable shredding in even the most compact of spaces. Due to the motor being mounted above the XRipper, the footprint required for the XRP is kept to a minimum, allowing simple installation even in narrow shafts; meanwhile, the clever design concept ensures excellent accessibility when maintenance work is required: The entire functional unit is simply lifted out while the machine body remains firmly screwed onto the pipe system.

- Twin-shaft shredder with low installation depth, vertically attached rotors and motor installed above this
- Suitable for inline use in pipes where space is particularly tight

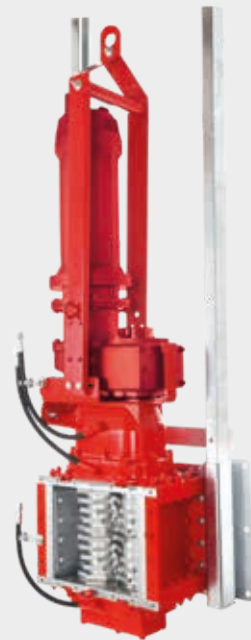

### **XRipper® XRC-SIK**

#### **The user-friendly version for open sewers and ducts**

The XRC is ideal for installation in open sewer, ducts and/or intake or inflow structures. The flexible Sewage Integration Kit (SIK) means it can also be easily positioned against slanted or even rounded walls directly in front of the inlet and/or outlet. For maintenance and service, the entire grinder is simply raised out using the SIK.

- Simple removal and positioning with the Sewer Integration Kit
- Ideal for high flow rates such as in sewer, ducts and inlet or inflow of sewage treatment plants



### **XRipper® XRG**

#### **A giant for maximum flow rates**

The XRG provides safe and highly efficient protection from solid and disruptive matter in wastewater at extremely high volume flows such as in large channels and in inflow lines of sewage treatment plants. The HighCapacity units at the side enable large quantities of (waste) water to pass by unobstructed. Disruptive matter and debris are held back reliably and led to the Ripper rotors which then shred it to a manageable size.

- Twin-shaft shredder for extremely high flow rates thanks to HighCapacity units
- Safe separation and shredding of disruptive matter



Cutting head with ACC plus

# Fault-free cutting edge and reliable

**The RotaCut® with integrated heavy material separator – for homogeneous sludge and low maintenance costs**

Long-fibered materials, hair and similar disruptive matter often lead to entangled material, which causes clogging in wastewater pump stations, during digester recirculation or intake of feces. Even when thickening sludge with decanters and separators, entangled material has a negative effect on dewatering and operational safety. If stones and metal are also present in sludge or wastewater, this not only impairs system performance but can also lead, in the worst cases, to a total failure of components and subsystems.

The RotaCut separates critical heavy material before it can cause any damage. Disruptive matter contained in wastewater or sludge is macerated and fibrous components are reliably treated and homogenized. This prevents floating layers, entangled material and clogging, ensuring efficient operation of the plant.

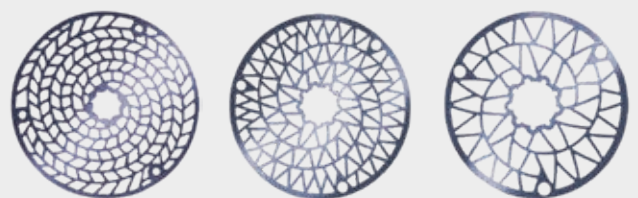
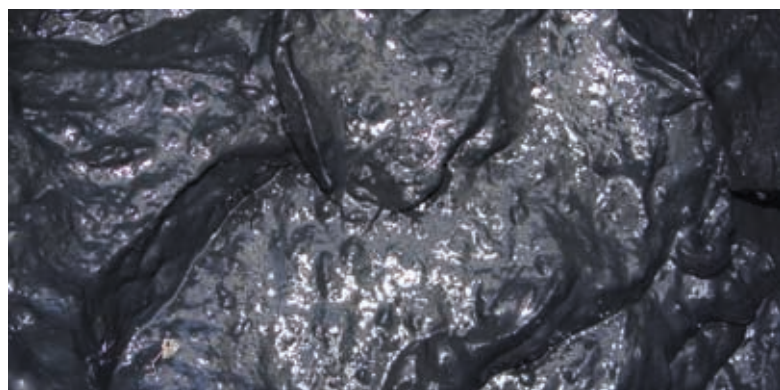

Cutting screens with an optimal geometry allow optimal adaptation to the medium and the desired size-reduction ratio.

## **Advantages of the RotaCut®**

- Prevents floating layers, entangled material and blockages by macerating fibers and coarse matter
- All downstream equipment is protected from foreign matter thanks to an integrated heavy material separator
- Homogeneous and better flowing sludge means a lower pump power is required

### The principle

The RotaCut is a macerator for wastewater and sludge that combines two functions: It separates and chops down, enabling media burdened with foreign bodies, disruptive matter and fibrous solid matter to be treated to create a simple-to-pump suspension. While the medium continually flows through the RotaCut, heavy material such as stones or metal parts are separated out by gravity. They are easily removed later through a cleaning port. All floating and suspended substances within the medium – fibers, hair, non-woven and fabrics, wood, entangled material – are transported to the cutting screen by the liquid and macerated by rotating, self-sharpening blades. The medium is homogenized at the same time.

### ACC Constant performance, long service life

Automatic Cut Control (ACC) consistently ensures excellent cutting performance by the RotaCut. There's no need for manual maintenance as the ACC automatically adjusts the blades of the RotaCut and keeps the necessary contact pressure constant – as high as necessary and as low as possible. This means the pressure can be adapted to the medium at any time without interrupting operation, which not only reduces power consumption requirements but also reduces wear and significantly extends the life of the blades.

### Always informed with ACC plus

The optional ACC plus feature enables online monitoring of the RotaCut for the RCQ and RCX series. An external display and/or the control graphically indicates the status of the blades and informs you when the blades require changing, so you can plan spare parts orders and maintenance well in advance.

ACC systems are, therefore, the foundation of efficiency gains and the greatest degree of automation for continuous use applications.

### Performance Control Unit (PCU):

#### Efficiency through intelligence

If multiple pumps and grinders are grouped together into one unit, the PCU checks processes in the unit, as well as other parameters. It ensures optimum communication between individual pumps and grinders and continuously monitors their loads. Individual components are controlled to ensure that the unit as a whole achieves optimum results. The PCU detects faults early on and rectifies them before they pose a problem – fully automatically.

The control system communicates quickly with higher-level systems via PROFINET, enabling the central collection and evaluation of detailed operating data. The OPC UA interface enables platform-independent data exchange or access for remote maintenance. The easy-to-understand Human Machine Interface (HMI) is based on visual elements and, with its intuitive user interface, displays operating states, data and settings at a glance.

Operators profit from both fully automated and situation-based control of operating parameters and, at the same time, from location-independent monitoring of remote pumping stations and unmanned sewage treatment plants.



RCQ-33G Inline



RC 10000 Compact XL

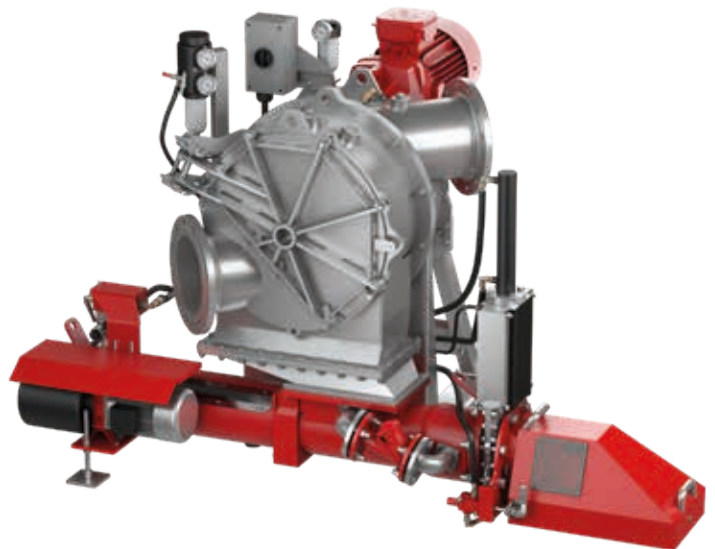

RCX-58G with DRS

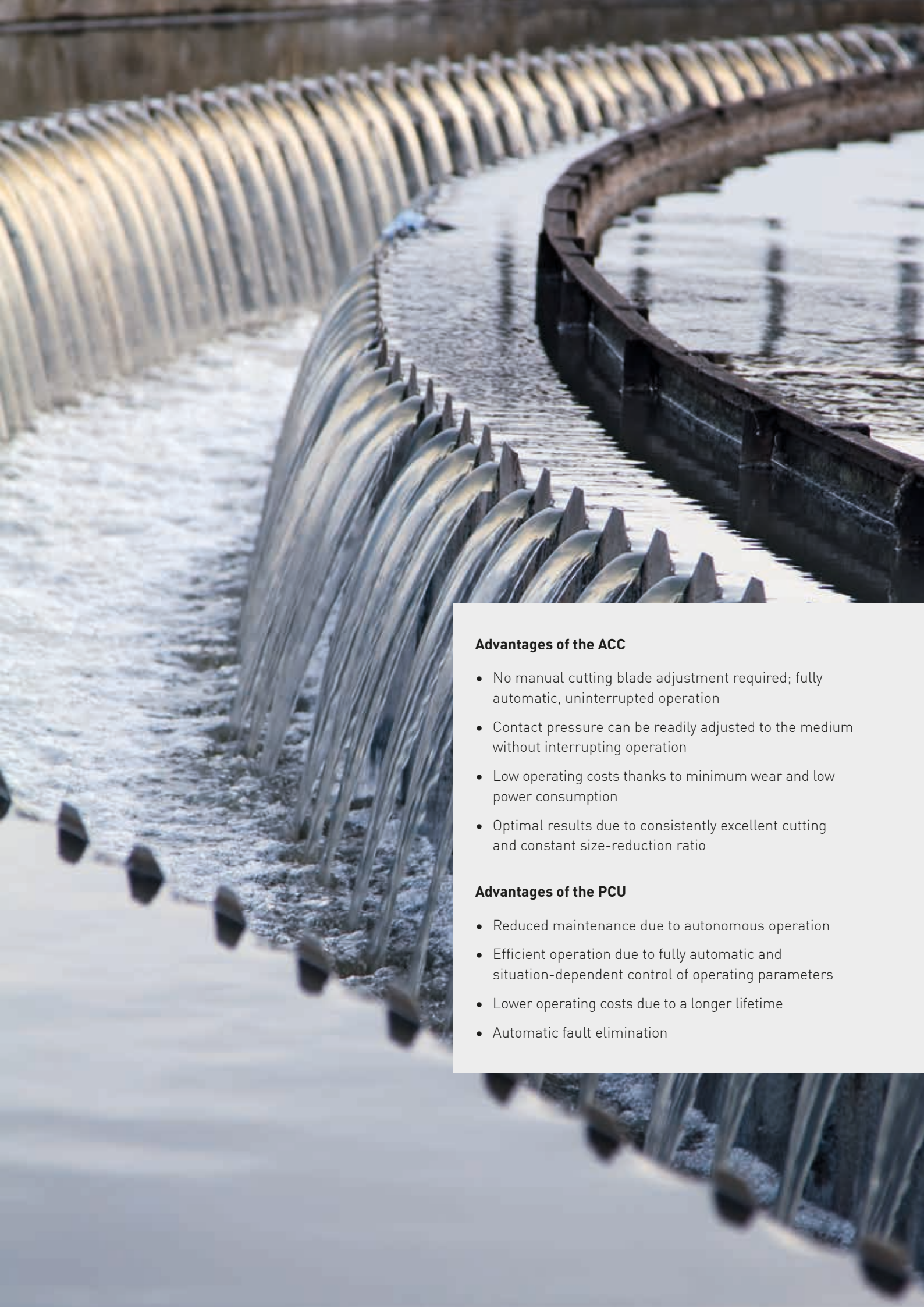

#### **Advantages of the ACC**

- No manual cutting blade adjustment required; fully automatic, uninterrupted operation
- Contact pressure can be readily adjusted to the medium without interrupting operation
- Low operating costs thanks to minimum wear and low power consumption
- Optimal results due to consistently excellent cutting and constant size-reduction ratio

#### **Advantages of the PCU**

- Reduced maintenance due to autonomous operation
- Efficient operation due to fully automatic and situation-dependent control of operating parameters
- Lower operating costs due to a longer lifetime
- Automatic fault elimination

# When it comes to service, we leave nothing to chance

## Comprehensive services for smooth operation and a long lifetime

### Support and supply from A to Z

Because we are aware that close customer proximity is essential for our mutual success, we design our services to best meet your needs. In Germany and in countries where we have subsidiaries, Vogelsang service centers and contractual partners generate an active dialog with our customers and provide reliable support.

This means you always get the precise support you need in every phase of our partnership. Our highly qualified staff make it possible – experts such as consultants and technicians who know your Vogelsang machines inside and out.



Since its establishment in 1929, Vogelsang has become an internationally recognized mechanical engineering company with numerous branches, sales centers and subsidiaries.



### **We think ahead**

Thinking ahead in your best interest begins with our extensive and detailed product documentation. Spare parts are available within a short time due to our high degree of vertical integration in production. In addition, you will always find an authorized service partner in your area who can help with repairs and wear part replacement. The Vogelsang ServicePack completes the offer. Whether you need start-up, on-site training, training at the Vogelsang facility, or full service support with a maintenance contract and a wear parts service package – we offer a support program tailored specifically to your needs.

## What we offer

We provide solutions in the following sectors:  
AGRICULTURAL TECHNOLOGY, BIOGAS,  
INDUSTRY, TRANSPORTATION, WASTEWATER



## Our broad range of products and services

- Consulting and service
- Data management and control technology
- Disintegration technology
- Individually tailored solutions for special applications
- Pumps and pump systems
- Solid matter feeders
- Spreading technology
- Supply and disposal systems for railway, busses and boats
- Wet grinders and solids reduction as well as separation technology

Copyright 2025 Vogelsang GmbH & Co. KG

Product availability, appearance, technical specifications and details are subject to continuous development. All information presented here is therefore subject to change. In selected countries, Vogelsang®, BioCut®, BlackBird®, CC-Serie®, EnergyJet®, HiCone®, PreMix®, RotaCut®, XRipper®, XSplit® and XTill® are registered trademarks of Vogelsang GmbH & Co. KG, Essen (Oldenburg), Germany. All rights reserved, including the rights to all graphics and images.

Solution-based wastewater technology\_EN-INT\_09207725\_MET0000696 – Printed in Germany

Vogelsang GmbH & Co. KG  
Holthoeye 10 – 14 | 49632 Essen (Oldenburg) | Germany  
Phone: +49 5434 83 - 0 | Fax: +49 5434 83 -10  
germany@vogelsang.info

[vogelsang.info](http://vogelsang.info)





# SPECIFICATION

## SOLUTION-BASED WASTEWATER TECHNOLOGY

Pumps and grinders for sewage treatment plants  
and sewer system

VOGELSANG – LEADING IN TECHNOLOGY

# VX series

Vogelsang VX series rotary lobe pumps –  
proven reliable in the widest variety of pumping tasks

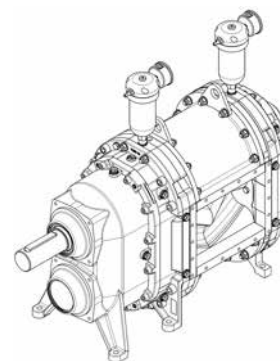

Type	Stroke volume	Max. capacity*		Max. pressure		Max. speed	Max. shaft deflection	
		l/rev.	m <sup>3</sup> /h	l/min	Q bar		QD bar	Q mm/bar
<b>VX100 series</b>								
45	0.29	17	290	10		1,000	0.01	
64	0.42	25	420	9		1,000	0.02	
90	0.59	35	590	7		1,000	0.04	
128	0.84	50	840	4		1,000	0.08	
<b>VX136 series</b>								
70	1.27	61	1,016	10		800	0.01	0.002
105	1.90	91	1,520	10	12	800	0.03	0.004
140	2.53	121	2,024	8	12	800	0.05	0.007
210	3.80	182	3,040	5	10	800	0.16	0.016
280	5.06	243	4,048		8	800		0.031
420	7.59	364	6,072		6	800		0.090
<b>VX186 series</b>								
92	3.56	128	2,136	10		600	0.01	
130	5.03	181	3,018	10	12	600	0.02	0.003
184	7.12	256	4,272	8	12	600	0.05	0.008
260	10.06	362	6,036	5	10	600	0.12	0.012
368	14.24	513	8,544	2 (3**)	8	600	0.33	0.028
390	15.09	543	9,054	2 (3**)	7	600	0.40	0.028
520	20.12	724	12,072		6	600		0.069
736	28.48	1,025	17,088		3	600		0.191
<b>VX215 series</b>								
226	15.47	501	8,354	5	12	540	0.10	0.010
320	21.88	708	11,815	2.5	10	540	0.29	0.026
452	30.94	1,002	16,708		10	540		0.063
640	43.76	1,417	23,630		6	540		0.167
<b>VX230 series</b>								
226	13.45	436	7,263	8	12	540	0.05	0.006
320	19.04	617	10,282	5	10	540	0.13	0.012
452	26.90	872	14,526		10	540		0.029
640	38.08	1,234	20,563		6	540		0.073

\* Maximum theoretical capacity. In practice, the capacity is normally lower, depending on pressure difference, medium viscosity and pump installation. We would be happy to configure the best rotary lobe pump for your application with the help of our computer-assisted sizing software.

\*\* Not in continuous operation.

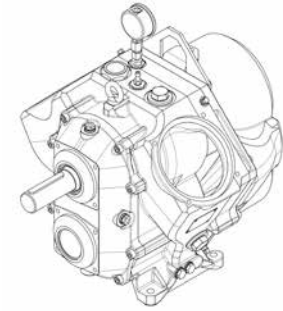

# IQ series

Greater cost-effectiveness thanks to reduced maintenance and service

Type	Stroke volume	Max. capacity*		Max. pressure	Max. speed	Max. shaft deflection
		m <sup>3</sup> /h	l/min			
	l/rev.	m <sup>3</sup> /h	l/min	bar	min <sup>-1</sup>	mm/bar
<b>IQ112 series</b>						
81	1.02	55	918	7	900	0.04
114	1.44	78	1,296	5	900	0.08
<b>IQ152 series</b>						
112	2.61	110	1,827	7	700	0.03
158	3.67	154	2,569	5	700	0.08

\* Maximum theoretical capacity. In practice, the capacity is normally lower, depending on pressure difference, medium viscosity and pump installation. We would be happy to configure the best rotary lobe pump for your application with the help of our computer-assisted sizing software.

# HiCone®

The revolutionary progressive cavity pump with unrivaled low operating costs

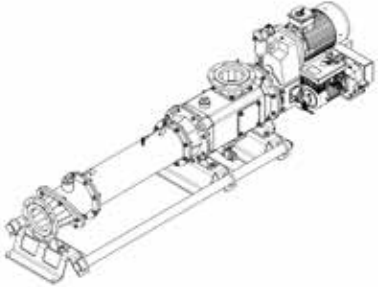

Type	Max. capacity*	Max. pressure	Max. free passage
HiCone 44	37	12	48
HiCone 55	75	12	62
HiCone 66	150	12	78
HiCone 77	290	12	98

\* Maximum theoretical capacity. In practice, the capacity is normally lower, depending on pressure difference, medium viscosity and pump installation. We would be happy to configure the best progressive cavity pump for your application with the help of our computer-assisted sizing software.

# XRipper®

The XRipper® wastewater grinder – reliable protection against clogging

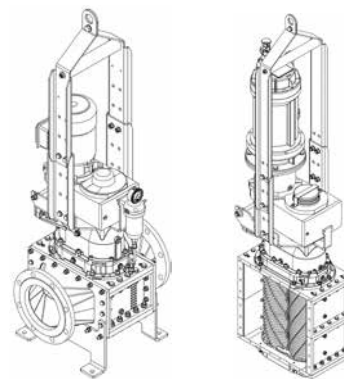

Type	Blade widths	Drive power	Drive speed	Max. throughput*	Max. pressure	Inlet opening / Total width
	mm	kW	min <sup>-1</sup>	m <sup>3</sup> /h	bar	mm
<b>XRipper XRS</b>						
100	5.5 7.4	1.5	53	50	8	Ø 100
136	6.2 9.8	2.2	41	110	8	Ø 150
186	7.9 10.4	4.0	40	325	8	Ø 150   200
<b>XRipper XRP</b>						
100	5.5 7.4	1.5	57	85	8	Ø 100
136	5.9 6.2 9.5 9.8**	2.2 4.0	46 45	300	6	Ø 100   150   200
186	7.9 10.6	4.0 5.5 7.5	38 36 41	1,140	4	Ø 250   300   400   450
<b>XRipper XRC</b>						
100	5.5	2.2	50	690		298
136	9.8	3.0	44	940		460
186	9.8	4.0	34	1,770		600
<b>XRipper XRG</b>						
100+HCS	5.5	2.45	51	1,164		530
136+HCS	9.8	4.25	45	2,431		740
136+HCD	9.8	4.5	45	3,300		1,060
186+HCD	9.8	6.6	36	7,164		1,370

\* Maximum theoretical throughput for water and a pressure loss of 0.25 bar with the XRS or 0.15 bar with the XRP or optimale sewer conditions (XRC and XRG).

\*\* Depending on the exact type. We would be happy to configure the best grinder for your application with the help of our computer-assisted design software.

# RotaCut®

The RotaCut® macerator with integrated heavy material separator – for reliable processes and low maintenance costs



Type	Max. throughput*	Optional speed	Optional drive power	Hydraulic motor	Heavy material separator / available design	Cutting screen with available free passage
	m <sup>3</sup> /h	min <sup>-1</sup>	kW			mm
RCQ-20	90	87-320	1.1-2.2		Inline	10 15 20
RC 3000	180	76-326	1.5-4.0	x	Inline, MXL	4 8 10 12 15 20 28
RCQ-26	180	72-326	2.2-5.5		Inline	4 8 10 12 15 20 28
RC 5000	300	66-330	1.5-7.5	x	Inline, Compact XL, MXL, M/MX	4 6 8 10 12 15 24 30
RCQ-33	300	72-326	2.2-7.5		Inline, Compact XL	4 6 8 10 12 15 24 30
RC 10000	600	66-319	2.2-7.5	x	Inline, Compact XL, MXL	4 8 10 12 16 20 25 34 38
RCQ-43	600	115-292	5.5-7.5		Inline, Compact XL	4 8 10 12 16 20 25 34 38
RCX-48	600	114-311	5.5-11		RCX, DRS	4 8 10 12 16 20 25 34 38
RCX-58	780	94-276	7.5-15	x	RCX, DRS, MXL	4 8 10 12 16 25 34 40 50
RCX-68	1,200	98-243	11-18.5		RCX, DRS	30 40 50

\* Throughput depending on DS content.

## What we offer

We provide solutions in the following sectors:  
AGRICULTURAL TECHNOLOGY, BIOGAS,  
INDUSTRY, TRANSPORTATION, WASTEWATER



## Our broad range of products and services

- Consulting and service
- Data management and control technology
- Disintegration technology
- Individually tailored solutions for special applications
- Pumps and pump systems
- Solid matter feeders
- Spreading technology
- Supply and disposal systems for railway, busses and boats
- Wet grinders and solids reduction as well as separation technology

Copyright 2025 Vogelsang GmbH & Co. KG

Product availability, appearance, technical specifications and details are subject to continuous development. All information presented here is therefore subject to change. In selected countries, Vogelsang®, BioCut®, BlackBird®, CC-Serie®, EnergyJet®, HiCone®, PreMix®, RotaCut®, XRipper®, XSplit® and XTill® are registered trademarks of Vogelsang GmbH & Co. KG, Essen (Oldenburg), Germany. All rights reserved, including the rights to all graphics and images.

Solution-based wastewater technology\_TD\_EN\_09207725\_MET0000380 – Printed in Germany

Vogelsang GmbH & Co. KG  
Holthoeye 10 – 14 | 49632 Essen (Oldenburg) | Germany  
Phone: +49 5434 83 - 0 | Fax: +49 5434 83 -10  
germany@vogelsang.info

[vogelsang.info](http://vogelsang.info)

